

PORTFOLIO · 2026

Shilpi *Sharma*

Interior Designer



ABOUT

Designing rooms the way people *actually live in them.*

I'm in the final semester of a Master of Vocation (M.Voc / MBA-equivalent) in Interior Design at Mangalayatan University, graduating in two months.

My process starts on paper — I still prefer manual drafting for residential and commercial layouts — and moves through CAD documentation, 3D modelling in SketchUp and 3ds Max, and photoreal rendering in V-Ray. I care most about material palettes, proportion, and how a space is lit.

— *Shilpi*

50+

DRAWINGS & RENDERS

5

D & CAD TOOLS

2 mo

UNTIL GRADUATION

04 RESIDENTIAL & COMMERCIAL

Featured Renders.

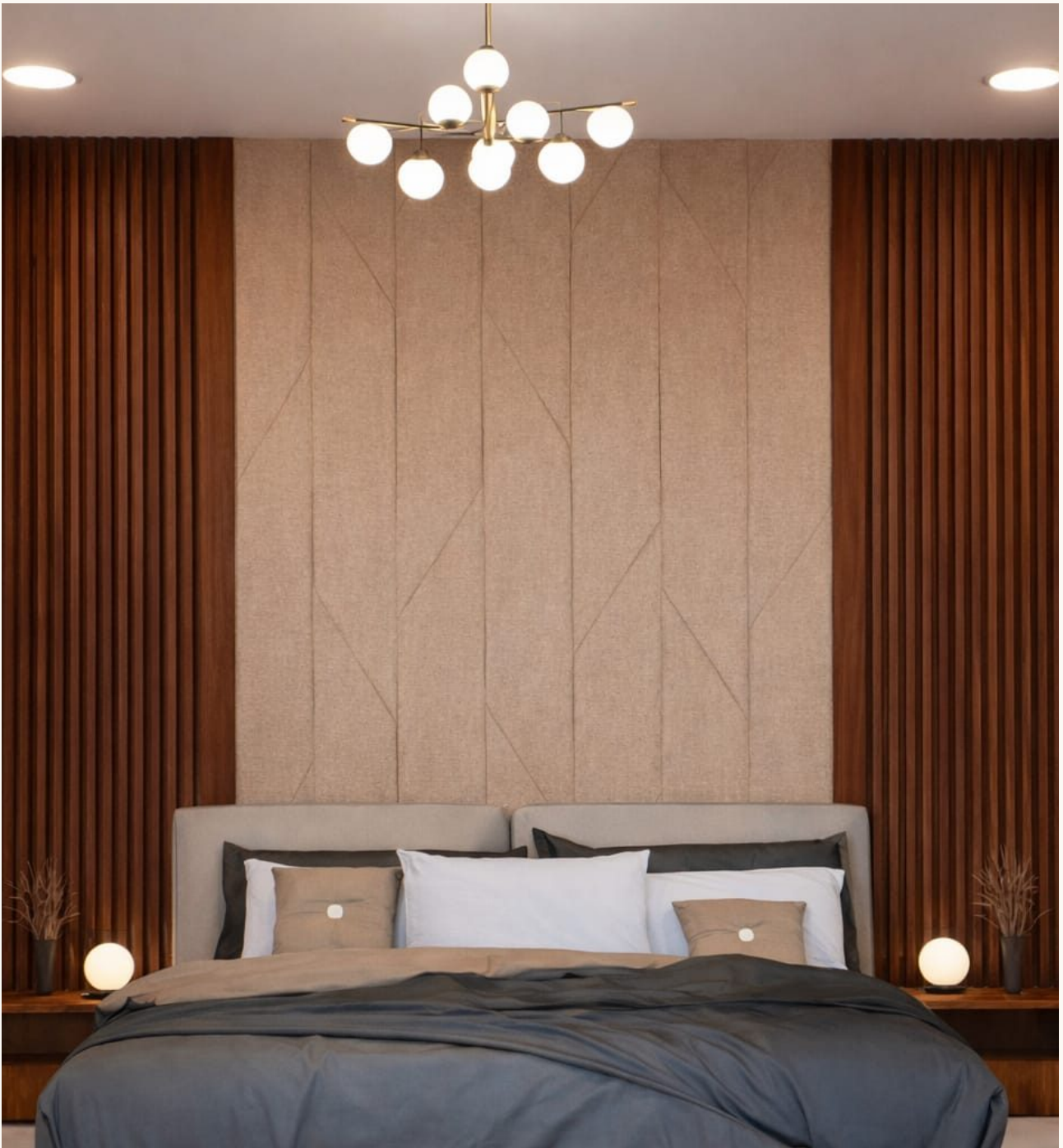

RESIDENTIAL · MASTER BEDROOM

The Fluted Retreat

A calming master suite built around a tailored linen headboard, warm teak fluting, and soft globe lighting. The vertical fluting visually raises the ceiling in a compact floor plate, while three layers of light (downlights, chandelier, bedside orbs) give the room an intimate hotel quality.

SKETCHUP · V-RAY · AUTOCAD



RESIDENTIAL · BATHROOM

Warm Stone Bathroom

A small guest bathroom designed to feel like a private spa. Terrazzo accent walls pair with a walnut-veneer vanity and a charcoal walk-in shower; warm dimmable downlights hold the whole palette together.

SKETCHUP · V-RAY



COMMERCIAL · CAFÉ

Chi Tha Visto — Café Concept

A 25-seat neighbourhood café anchored by arched floor-to-ceiling glazing and a perforated brass-tone screen wall. Low lounge seating and two-tops are arranged around a signage moment in a deep navy, warm-wood palette.

REVIT · SKETCHUP · V-RAY



RESIDENTIAL · LIVING ROOM

Classical Living Room

A formal living room built on symmetry and restraint — wall-mounted moulding rectangles behind a neutral sofa, a four-frame gallery, and a brass Sputnik chandelier against deep-teal walls. Modelled in 3ds Max and rendered in V-Ray.

3DS MAX · V-RAY

02 · SKETCHUP MODELS

Concept Studies.



ARCHES IN SAGE

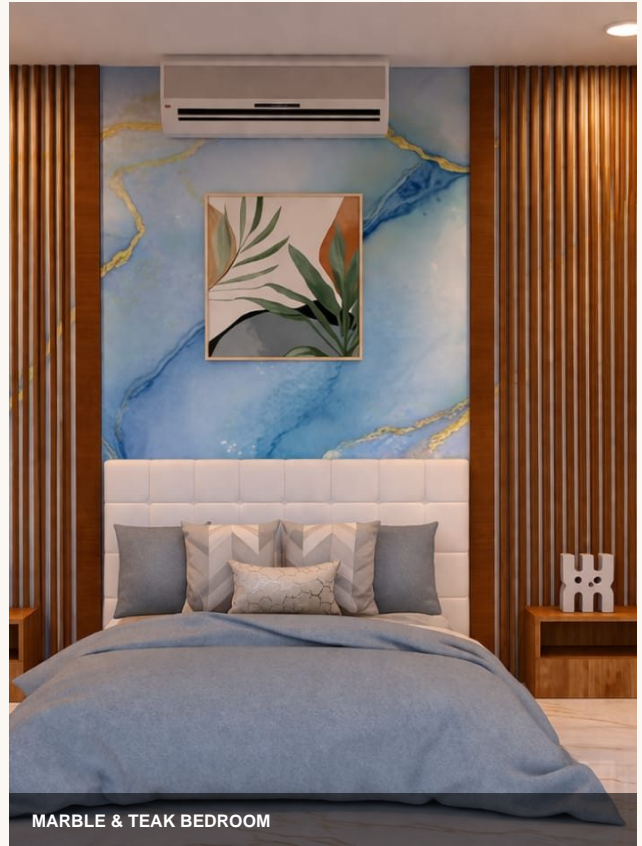

MARBLE & TEAK BEDROOM



OPEN KITCHEN · LATTICE

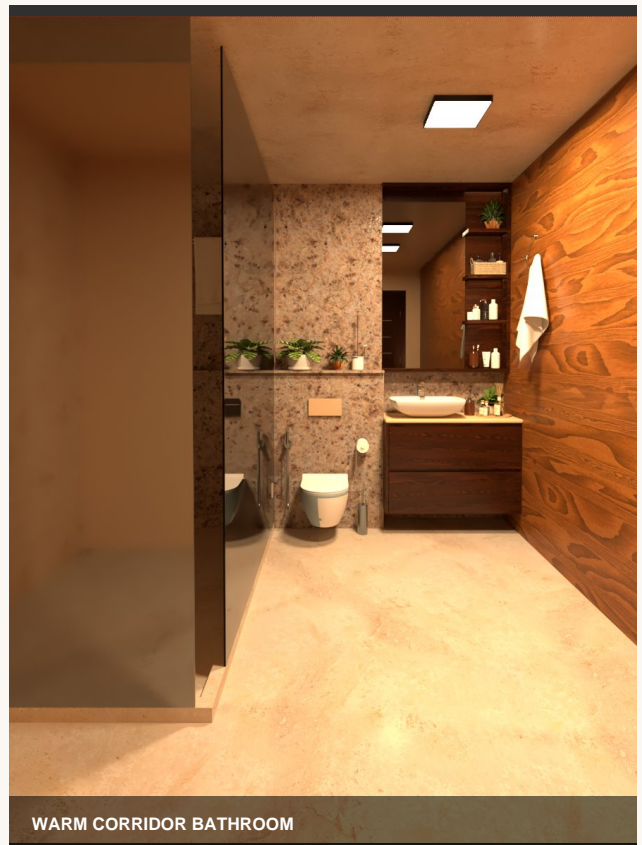

WARM CORRIDOR BATHROOM

MORE SKETCHUP CONCEPTS



MODULAR KITCHEN - GARDEN VIEW



KITCHEN + DINING

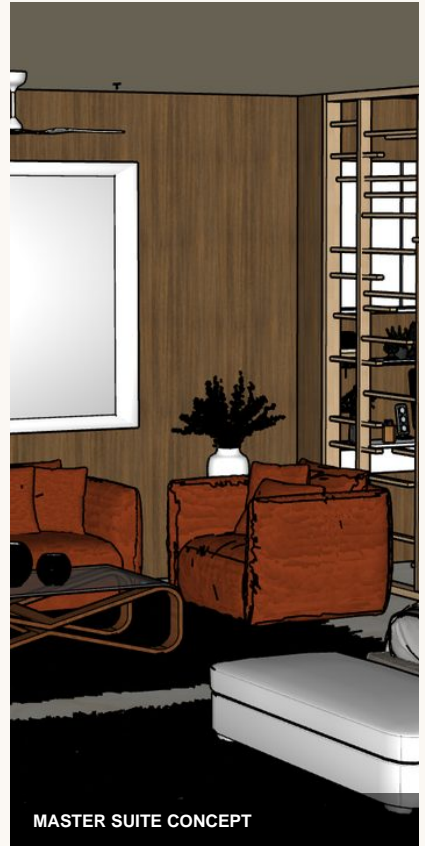

MASTER SUITE CONCEPT



SUITE WITH LOUNGE

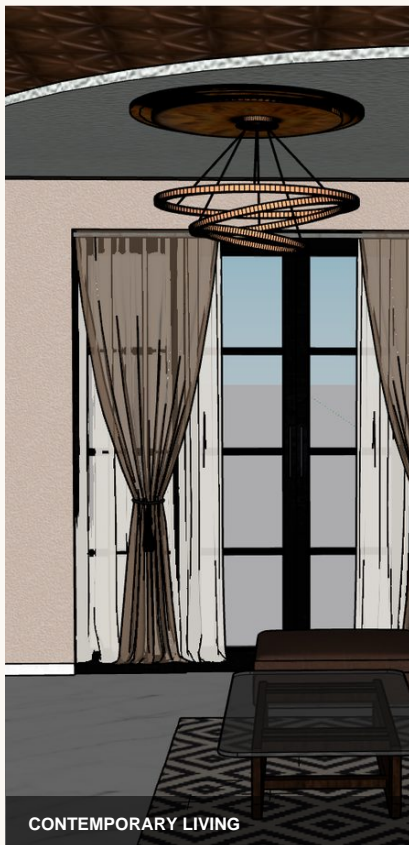

CONTEMPORARY LIVING



FEATURE TV WALL

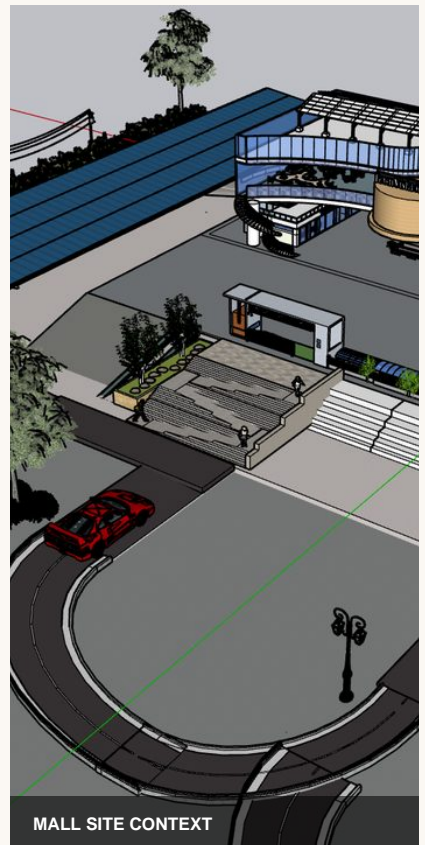

02 - AUTOCAD

Technical Drawings.

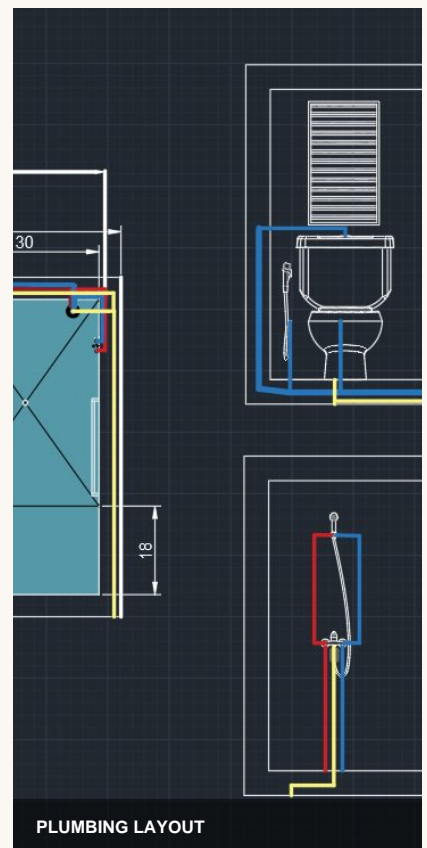
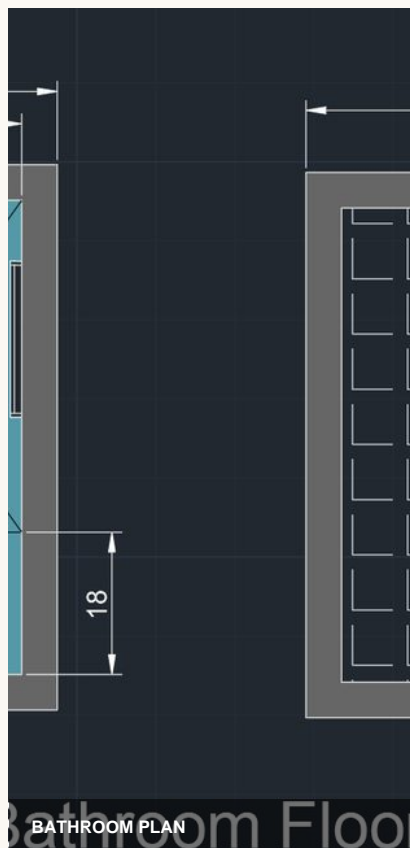
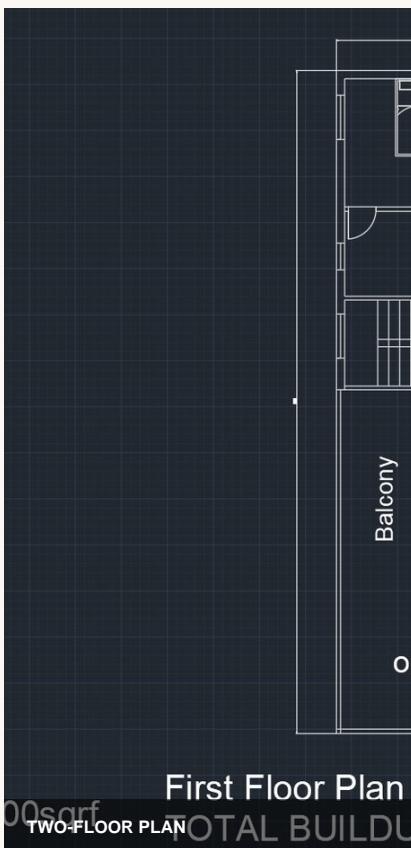
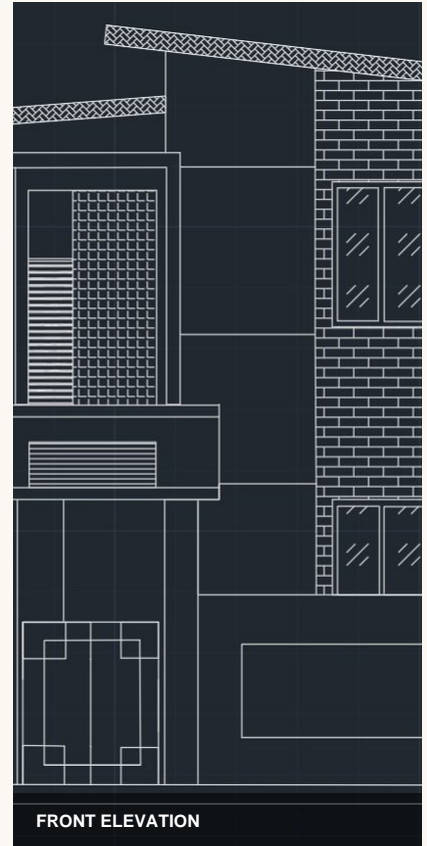
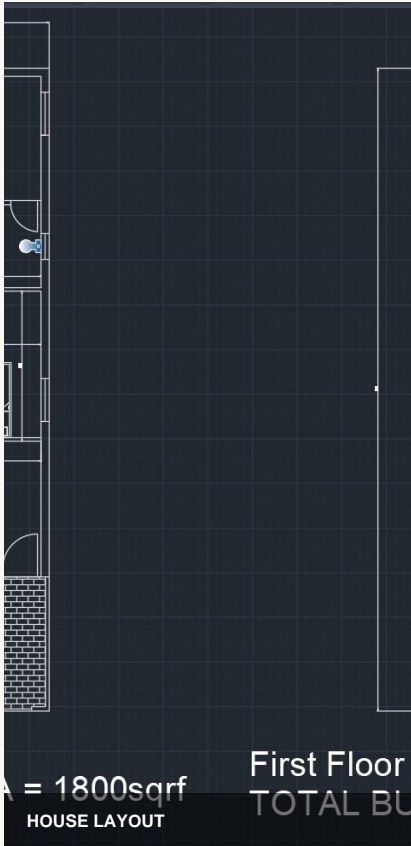

ROOM DETAILS

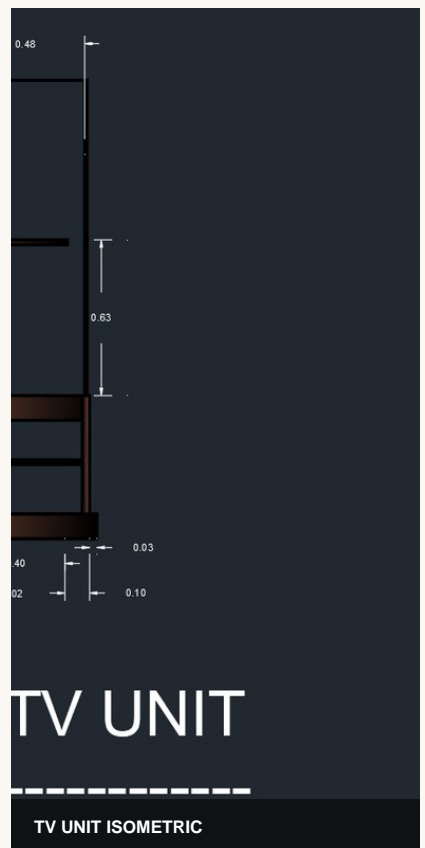
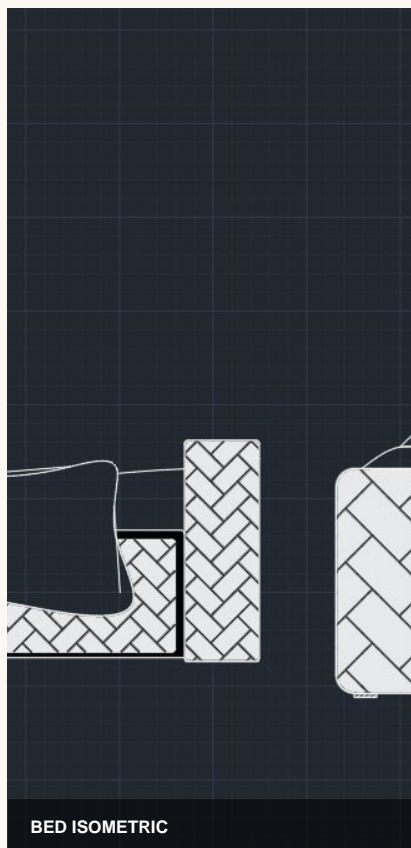
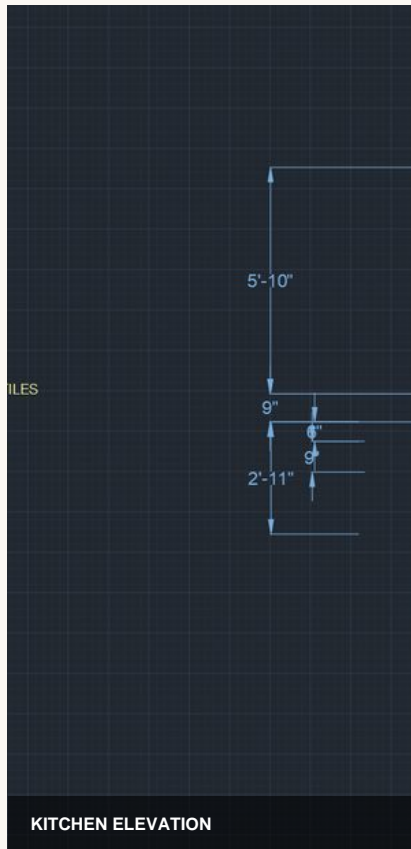
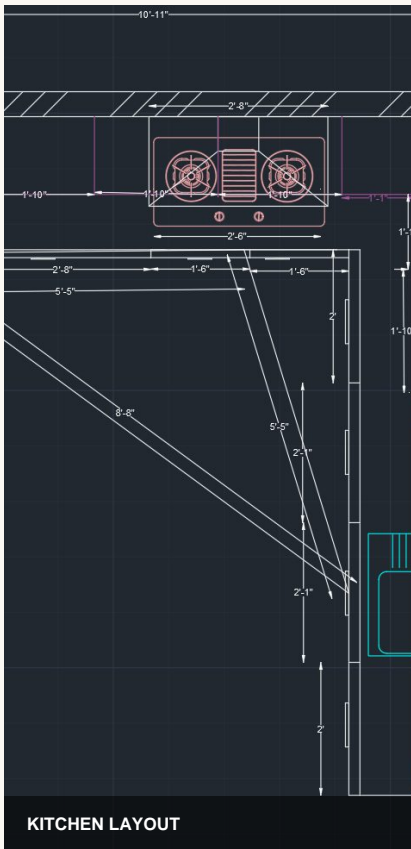

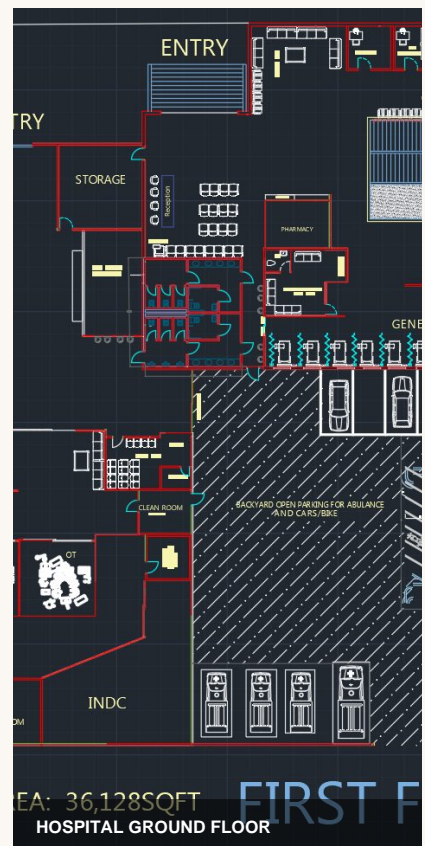
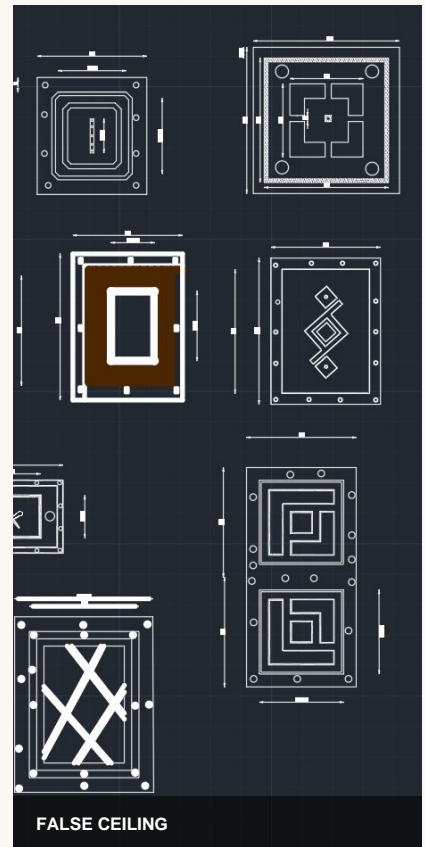
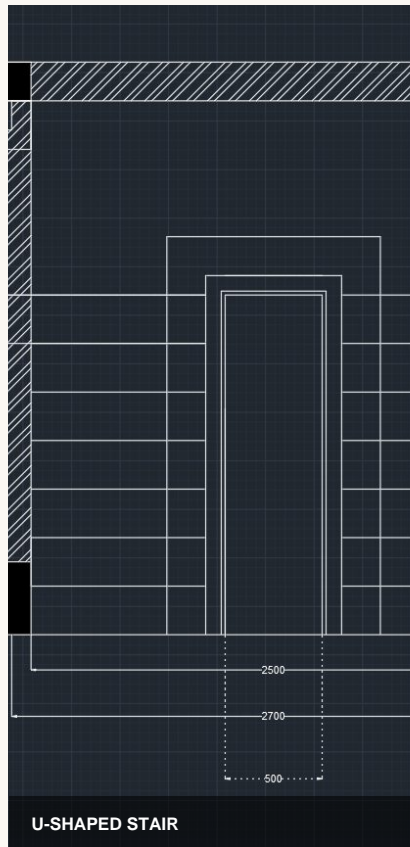
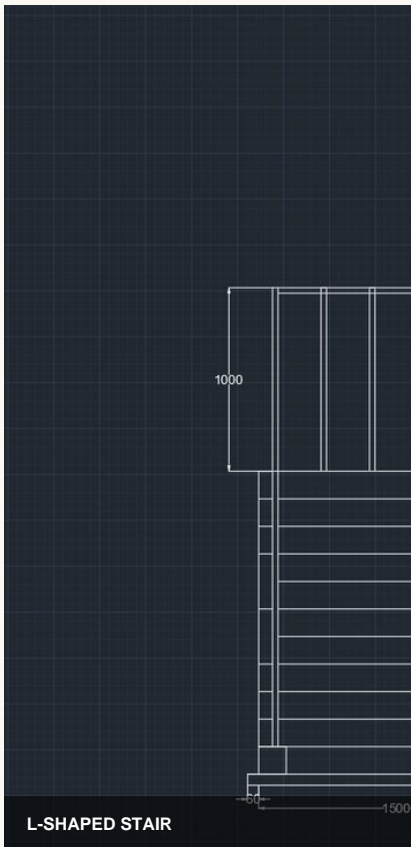

CAPABILITIES

Software & design skills.

Software

AutoCAD (2D & 3D)	ADVANCED
SketchUp	ADVANCED
3ds Max	INTERMEDIATE+
V-Ray	INTERMEDIATE+
Revit & Revit Map	INTERMEDIATE

Design Skills

Manual Drafting — Residential	STRONG
Manual Drafting — Commercial	STRONG
3D Visualisation	STRONG
Rendering & Post-Production	STRONG
Walkthrough Animation	DEVELOPING

Also comfortable with

Space planning

Material palettes

Lighting design

Mood boards

Working drawings

Furniture layouts

Isometric studies

False-ceiling detailing

Client presentations

EXPERIENCE & EDUCATION

Where I've been.

- **2024 — 2026 · FINAL SEMESTER**

M.Voc in Interior Design (MBA-equivalent)

Mangalayatan University

Two-year postgraduate programme covering space planning, technical drawing, 3D modelling, materials, services (plumbing & electrical layouts), and project management. Graduating in June 2026.

- **ACADEMIC STUDIO PROJECTS**

Residential & Commercial Design Studio

Coursework & Independent Briefs

Delivered full sets of residential interiors (bedrooms, kitchens, living rooms, bathrooms) and commercial projects (café, showroom, hospital, shopping centre) — from layout and elevation through 3D modelling and V-Ray render.

- **LOOKING FORWARD · 2026**

Open to Full-Time Roles

Interior Design Studios · Architecture Firms

Seeking a junior interior designer or 3D visualiser role where I can contribute to residential and commercial projects while continuing to grow in 3ds Max, V-Ray, and Revit.

GET IN TOUCH

Available from June 2026.

Email: kshilpi41@gmail.com

Phone: +91 7320855955